



Intellihot

Endless water. Zero waste.™

# Commercial

High-output, on-demand water heaters

**iQ Series, Gen II**



# Gen II - What's New



## Wi-Fi Connectivity

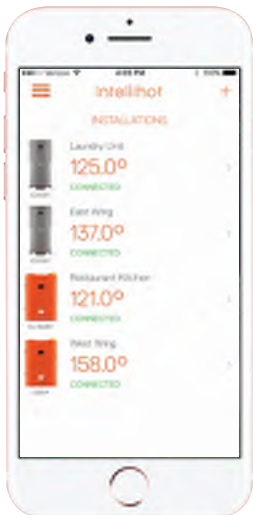

All Gen II units come equipped with Wi-Fi and 3G/4G connectivity. Each unit can be hooked up to your building's router or to Intellihot's internet hub. This enables remote access and monitoring of your units, like never before.

## Touch-Screen



All Gen II units have large, intuitive touch screens. All floor models have a 7" color touch-screen and all wall units have a 3.5" color touch-screen. Easily access daily, weekly, and monthly usage data, troubleshooting info, longevity of parts, and more.

## IOT App

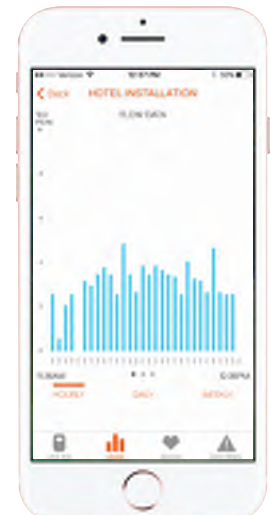

Download Intellihot's new IOT app, **telliZero**, and start monitoring your unit. Check water inlet/outlet temperatures, flow rates, flue gas temperatures, combustion rates, and more, all on your mobile device of choice.

# Why the iQ series?

## Industry-Best Capacity - Up to 1.5 Million BTUs

Our iQ Series floor-standing units deliver the highest capacity in on-demand water-heaters. Intellihot's most powerful model, iQ1501, delivers 1.5 million BTUs with no storage tanks required. The iQ1001 delivers 1 million Btu/hr and the iQ751 delivers 751,000 Btu/hr, both with no storage tanks. These high-input units are designed for very large volume, commercial applications.

Looking for the most powerful solution possible? Cascade four iQ1501 units together to create a 6 million BTU/hr system, or four iQ1001 units to create a 4 million BTU/hr system. Imagine what you can do with 160 GPM at 70°F rise, 24/7/365? The configuration possibilities are endless, and the performance is second to none.

## Slash CapEx by 50%, OpEx by 40%

With Intellihot systems, you slash capital costs by up to 50%, and reduce operational costs by up to 40%, when compared to traditional tank-type systems.

## Smart Modularity with Built-In Redundancy

Instead of sizing a water-heating system and then adding redundancy, you now have a far better option: our modular systems incorporate built-in redundancy, completely eliminating the need for oversizing. For example, each iQ1501 unit includes six independent heat engines that operate as an integrated system. If any one of the six internal modules experiences a malfunction, the remaining five will continue to operate - providing 83.3% of the original capacity. Similarly, iQ1001 has four individual heat engines. Using our patented masterless controls, we can eliminate single point failures and provide unmatched uptime to keep your business running 24/7/365.

## High Capacity in a Compact Unit

At 1025 lbs and 30" width (fits elevator doors), each iQ1501 supplies 40 GPM at 70°F temperature rise non-stop. Easily cascade and common vent four units together for 160 GPM at 70°F rise.

## Cycle-Proof and Scale-Free Heat Exchanger

Expandable 316L stainless steel heat exchanger handles thousands of thermal cycles and is built for thermal shocks. Patented vibration and constant circulation eliminate scale build-up and keep lime deposits in suspension, ensuring years of worry free operation.

## Self-Learning Systems, Intelligent BMS

Each Intellihot unit comes with iNTouch - an optional, factory-installed BMS (BacNET/Modbus) with self-learning building recirculation control. Intellihot's systems learn your building recirculation so they can automatically power on pumps and set the temperature to minimize cost without losing comfort. Cut pump power usage by 30% without sacrificing comfort.

## Works on Low 2.5" WC Gas Pressure

Our unique premix gas valve train can operate without any loss of capacity in very low gas pressures. No more failure to ignite.

## Rated for Indoor/Outdoor Installations

Intellihot's systems are built to withstand the elements and can be installed outdoors or indoors.

**Applications:** Hospitality, Multi-Family, Stadiums, Restaurants, Healthcare, Education, Retail, Manufacturing.



## Key Features

- 98% combustion efficiency minimizes energy costs, ensures green operation
- Turndown ratio of 25:1 for **iQ751**, 33:1 for **iQ1001**; 50:1 for **iQ1501**, for unparalleled gas savings
- Eliminate storage tanks, standby losses and mixing valves, and the risk of Legionella
- Full modulation/condensing
- Common venting capable
- ASME-HLW certified
- T&P relief valve and inlet water strainer included

## Masterless Cascading

The floor-standing **iQ** models have multiple heat engines by design. This modular design enables a key feature in our units, called “Masterless Cascading,” patented by Intellihot and available only in Intellihot’s **iQ** models. This feature enables us to meet large scale demand. This was achieved by reinventing basic communication between the heat engines and doing away with the traditional master-slave control approach. Each module or heat engine is always in peer-to-peer communication with others in the chain and together they decide by rotation, how to handle error codes, or how to meet the ever changing demands of hot water. Thus, Intellihot’s patented masterless cascading eliminates single point failures. Through a combination of modular devices, control strategies like masterless, and having devices automatically rotate and isolate themselves, we are able to achieve a very high degree of fail-safe reliability.

# Meet iQ251, Gen II

When space is at a premium, you can count on superior performance and reliability with our **iQ251** wall-hung, on-demand, water heater. Designed to be our commercial “workhorses,” these units are ideal for highly variable applications using potable hot water. Each unit is engineered with minimal components to maximize durability - even in the most demanding commercial applications. Installation of these models fits ideally where space is at a premium.

**Applications:** Laundromats, Restaurants - full service and fast food, Salons, Car Washes, Commercial Kitchens.



## iQ251 Key Features

- Wi-Fi enabled, 3.5" touch-screen, and mobile app to monitor and control remotely
- Cascade up to 2,510,000 BTU/hour (10 units) for larger applications
- 96% thermal efficiency
- Full modulation delivers maximum BTU/hour input when needed and zero BTU/hour the rest of the time
- Operates on very low gas pressure down to 2.5" WC
- Flexible design and circuit options
- Accommodates 3" PVC exhaust venting up to 130 feet (power vent)
- Common venting capable
- ASME-HLW certified
- T&P relief valve and inlet water strainer included

IQ751 | IQ1001 | IQ1501 Dimensional Specifications (Floor-Standing)

FRONT VIEW

REAR VIEW

WEIGHTS:

IQ751  
730 lbs

IQ1001  
800 lbs

IQ1501  
1025 lbs

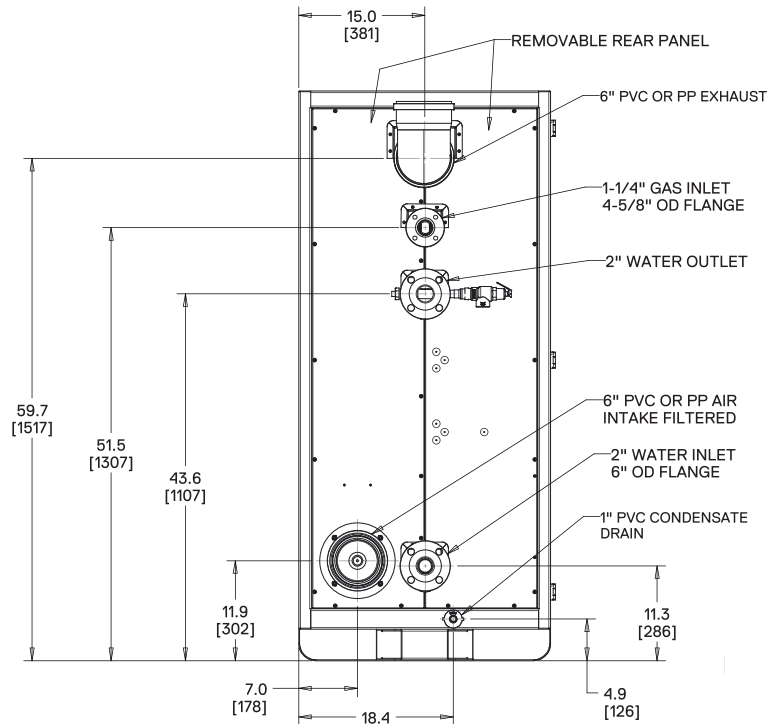
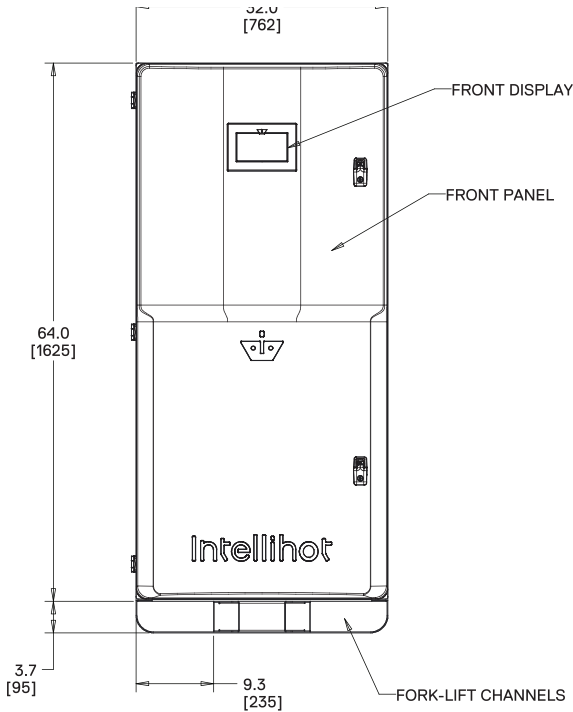

FRONT VIEW

REAR VIEW

IQ251 Dimensional Specifications (Wall-Hung)

FRONT VIEW

TOP VIEW

WEIGHT: 90 lbs

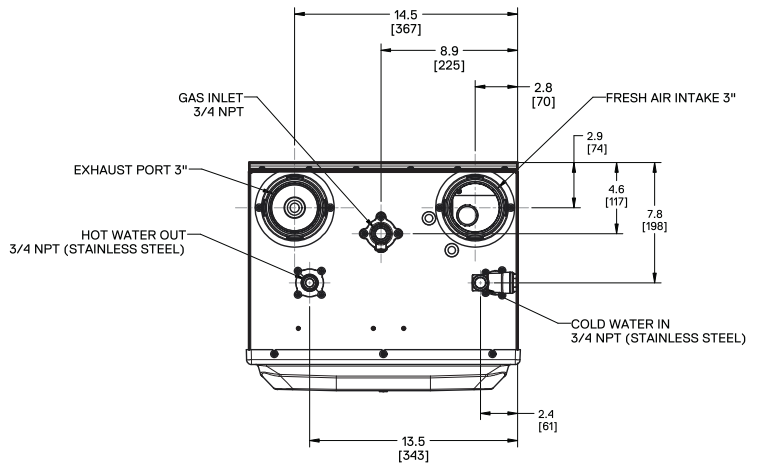
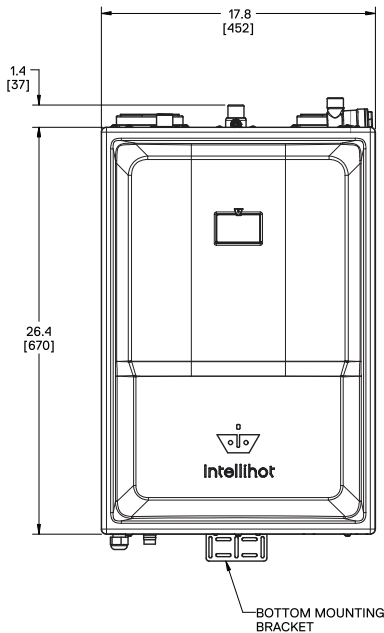

## iQ251 Technical Specifications (Wall-Hung)

PARAMETERS	iQ251
Type	Indoor/Outdoor, Wall Hung, Fully Condensing, On-demand Water Heater
Fuel	Preset for NG / LP convertible
Minimum / Maximum Input (BTUs/hour)	30,000 / 251,000
Thermal Efficiency	96%
Dimensions H X W X D (inches)	26 X 17.4 X 14.9 (3.9 cu. ft)
Weight (lbs)	90
Water Inlet / Outlet Connection	¾" NPT
Gas Inlet Connection	¾" NPT
Minimum Flow Rate for Activation	0.6 GPM
Ignition	Electronic Spark Ignition
Venting Type	Direct Vent (2 pipe – intake & exhaust), Power Vent (1 pipe – exhaust only)
Venting Materials	Sch. 40 PVC, Sch. 40 CPVC, Polypropylene, Stainless Steel (AL29-4C)
Max 3" Vent Length – Single Pipe / Power Vent	130 ft, deduct 5 ft per 90° elbow
Max 3" Vent Length – Two Pipe / Direct Vent	65 ft, deduct 5 ft per 90° elbow
Max 2" Vent Length – Single Pipe / Power Vent (2" not allowed at elevations above 4,000 ft)	N/A
Max 2" Vent Length – Two Pipe / Direct Vent (2" not allowed at elevations above 4,000 ft)	
Common Venting	Yes
Safety	Flame Rod, Thermal Fuse, Overheat Prevention Device, Fan Speed Monitor, Flue Temperature Monitor, Blocked Vent Detector, Water Shut-Off Valve, 2X10A Fuse, Dual Flame Sensing, Flue Damper
Water Pressure Min / Max (PSI)	30/160
NG/LP – Minimum Static Gas Pressure 1/2"	6" (non-corrugated, black iron)
NG/LP – Minimum Static Gas Pressure 3/4"	2.5" (non-corrugated, black iron)
NG/LP – Maximum Static Gas Pressure	14"
Gas Pressure for Adjustments	8" for NG, 11" for LP
Electrical	120V AC, 60 Hz
Power Consumption	500W (Max 4.2 Amps), 8W (Standby)
<b>Features</b>	<b>iQ251</b>
Listing	ETL (Z21.10.3 / CSA 4.3), ASME HLW
Cascading	Masterless, 10 units
Heat Exchanger	Expandable, Stainless 316L
<b>Performance GPM</b>	<b>iQ251</b>
Hot Water Capacity (35F Rise)	13.8
Hot Water Capacity (45F Rise)	10.7
Hot Water Capacity (77F Rise)	6.3
Domestic Mode Temp. Settings	100 – 140°F
Commercial Mode Temp. Settings	100 – 190°F
<b>Warranty (with recirculation, and unlimited thermal cycles)</b>	<b>Heat Exchanger Coil – 10 years, All Other Parts – 2 years, Labor - none</b>

Note: Due to Intertek's policy of continuous product improvements, design and technical specifications are subject to change without notice. Version 4.20.2017

 Designed in the heartland.  
 Built for the world.™

**iQ751 | iQ1001 | iQ1501 Technical Specifications (Floor-Standing)**

PARAMETERS	MODELS		
	iQ751	iQ1001	iQ1501
Type	Indoor/Outdoor, Floor Mounted, Condensing, Fully Modulating, On-demand Water Heater		
Fuel	Preset for NG / LP convertible without additional parts		
Minimum Input (BTUs/hour)	30,000		
Maximum Input (BTUs/hour)	751,000	1,001,000	1,501,000
Maximum Output (BTUs/hour)	705,940	940,940	1,380,920
Thermal Efficiency	94%	94%	92%
Turn Down Ratio (TDR)	25:1	33:1	50:1
Water Inlet / Outlet Connections	2" Headers with 6" OD Flange		
Gas Inlet Connection	1-1/4" Gas Inlet With 4-5/8" OD Flange		
Condensate Drain Connection	3/4" Flex PVC		
Maximum Condensate Flow Rate (GPH)	5.4	7.2	10.8
Dimensions H X W X D (inches)	64 X 30 X 43.4 (48 cu. ft)		64 X 30 X 59.6 (66 cu. ft)
Service Clearances	Recommend 24" on all sides, 32" in the front		
Weight (lbs)	730	800	1025
Venting Type	Direct Vent (2 pipe - intake & exhaust), Power Vent (1 pipe - exhaust only)		
Venting Materials (USA)	Sch. 40 PVC, Sch. 40 CPVC, Polypropylene, Stainless Steel (AL29-4C)		
Venting Materials (Canada)	Type BH Gas Vent Classes: II A (PVC), II B (CPVC), II C (Polypropylene), I (AL 29-4C SS)		
Vent Size (Diameter)	6" Ø		
Max 6" Vent Length - Single Pipe / Power Vent	220 ft*	130 ft*	65 ft
Max 6" Vent Length - Two Pipe / Direct Vent	110 ft*	65 ft*	35 ft
	* Venting Note: From the maximum lengths above, deduct 5 ft. per 90° elbow and 2 ft. per 45° elbow		
Ignition	Electronic Spark Ignition		
Temperature Range	100°F – 190°F		
Temperature Stability	+/- 4°F		
Installation Location Ambient Temperature	40°F – 130°F		
Safety	Flame Rod, Thermal Fuse, Overheat Prevention Device, Fan Speed Monitor, Flue Temperature Monitor, Blocked Vent Detector, Dual Flame Sensing		
Water Pressure Min / Max (PSIG)	30 / 160		
Pressure Relief Valve	3/4" Ø / Select Btu/h Input Rating to match Model Maximum Input / 160 PSIG		1"
NG/LP - Min. Dynamic Gas Pressure (Full Fire)	2.5" (non-corrugated, black iron)		
NG/LP - Maximum Static Gas Pressure	14"		
Gas Pressure for Adjustments	8" for NG, 11" for LP		
Electrical	120V AC, 60 Hz		
Power Consumption	Max 16 Amps, 24W (Standby)	Max 20 Amps, 32W (Standby)	Max 29 Amps, 48W (Standby)
Internal Water Volume (gallons)	4	4	6
<b>Features</b>	<b>iQ751</b>	<b>iQ1001</b>	<b>iQ1501</b>
High Turn Down	25:1	33:1	50:1
Built-In Redundancy	Multiple Heat Engines w/ Individual Control		
Cascading	Masterless, 4 units, Automatic Rotation		
Common Venting	Yes - up to 4 units		
Heat Exchanger	Expandable, Stainless 316L		
Listing	ETL (Z21.10.3 / CSA 4.3), ASME HLW		
<b>Performance GPM</b>	<b>iQ751</b>	<b>iQ1001</b>	<b>iQ1501</b>
Hot Water Capacity (45F Rise)	31.4	41.6	62.4
Hot Water Capacity (70F Rise)	20.2	26.7	40.1
Hot Water Capacity (90F Rise)	15.7	20.8	31.2
Hot Water Capacity (100F Rise)	14.1	18.7	28.1
Hot Water Capacity (140F Rise)	10.1	13.4	20.1
Warranty (with recirculation, and unlimited thermal cycles)	Heat Exchanger Coil – 10 years, All Other Parts – 2 years, Labor - none		

Note: Due to Intellihot's policy of continuous product improvements, design and technical specifications are subject to change without notice. Version 4/20/2017

